

INTELLIGENT CONTROL NETWORK IONIZING AIR BLOWER

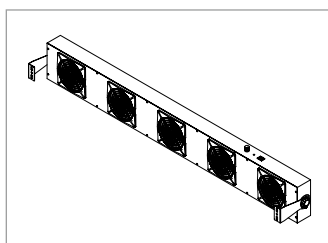

Suitable for electronics, optoelectronics, semiconductor and other industries

Effectively solve the problems caused by static electricity

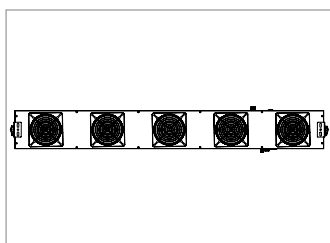
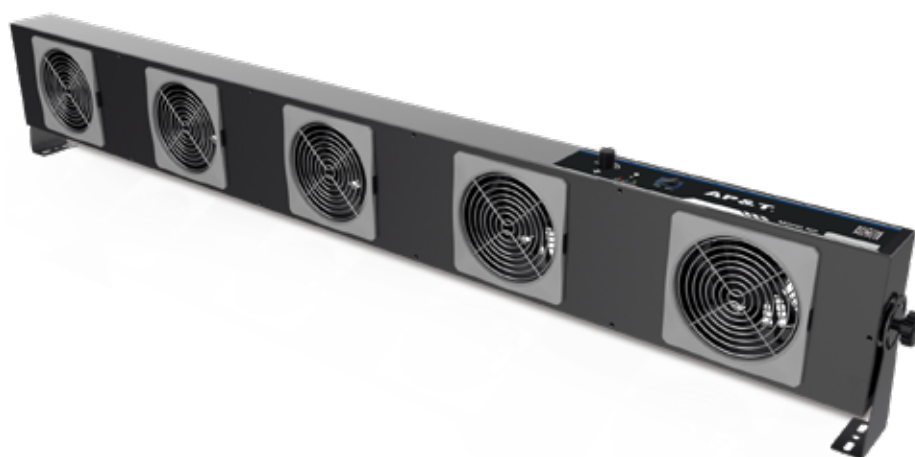
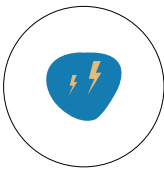

Static removal

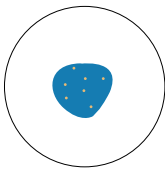

Prevent adhesion of objects

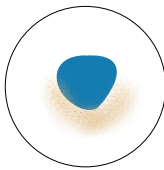

Prevent material splash

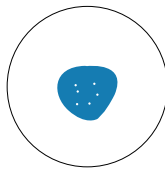

Prevent static electricity

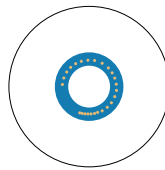

Prevent blockage of feeder

Network Monitoring

Monitoring the working status of ionizing air blower online

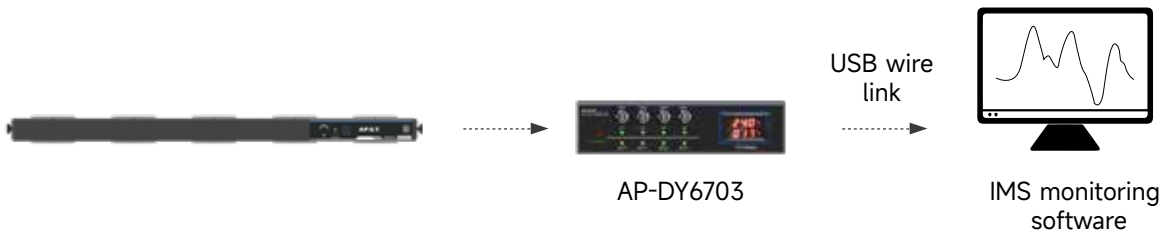
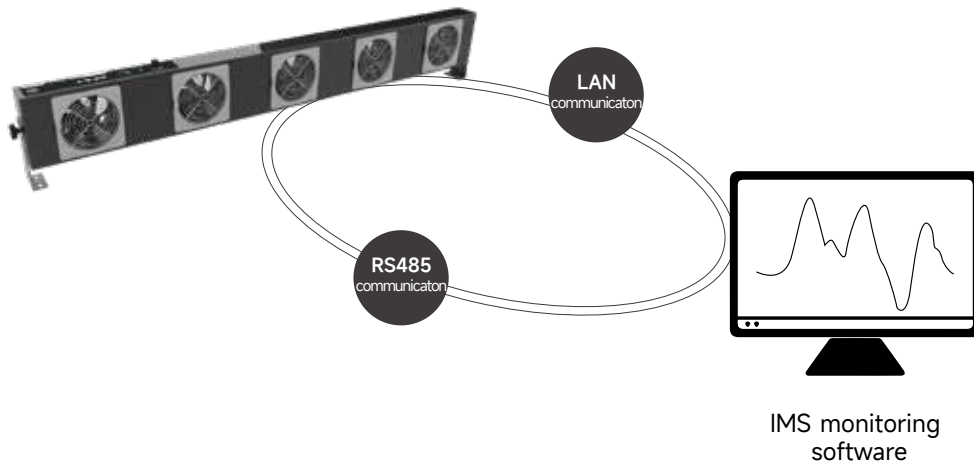

DC

The discharge effect is better compared to the high frequency AC ionizing air blower

◆ DC VS High frequency AC

DC method generate ions with two polarity by applying "+" and "-" high voltage on two electrode needles. The utilization rate of ion generation is high, the external electromagnetic interference is small and the pollution degree of the particulate matter in the purification environment is small.

Currently many ionizing air blowers in the market adopts high frequency AC. Due to the low discharge voltage and weak electric field, the dust resistance is poor, which is easy to cause corona occlusion and unable to eliminate static electricity.

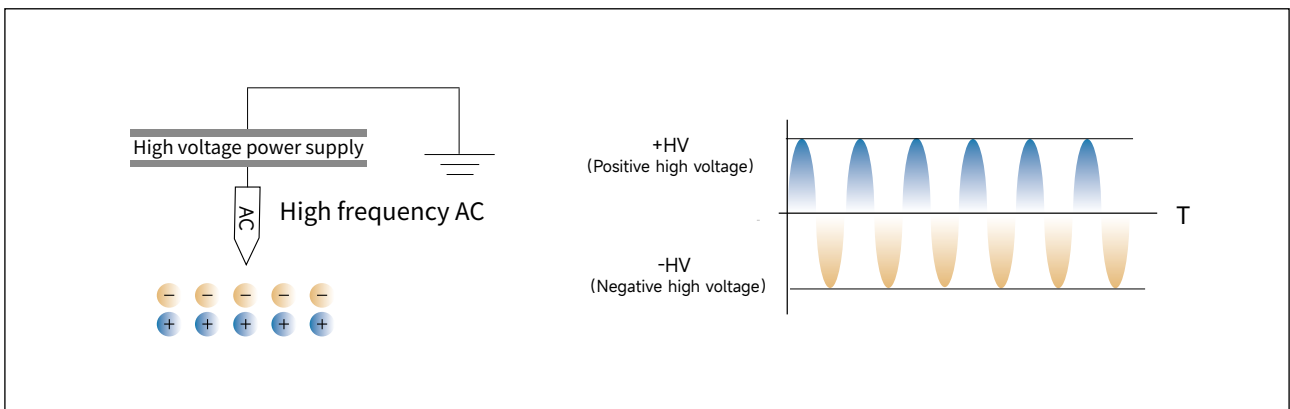
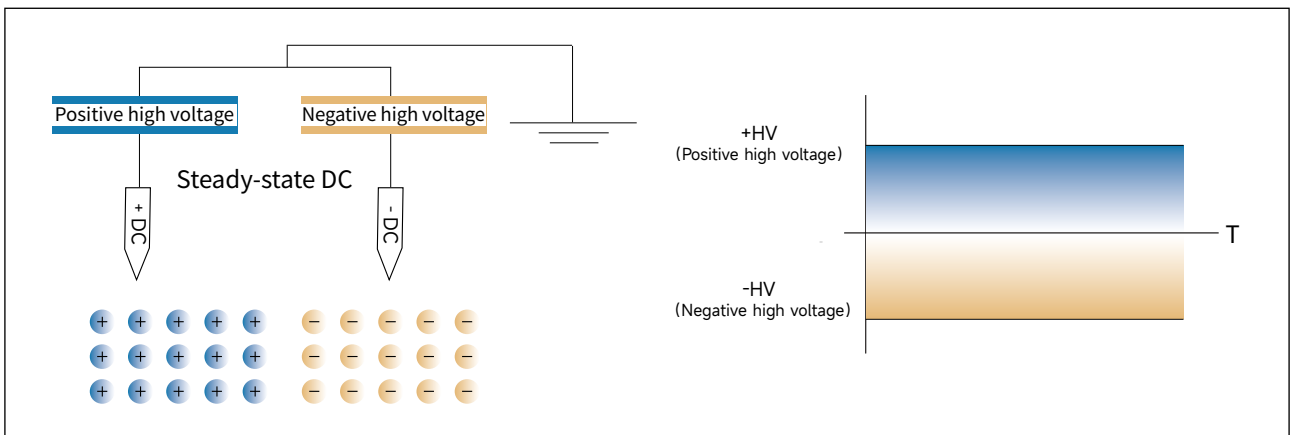

High Efficiency Static Removal

Keep a clean production environment and stay away from static electricity

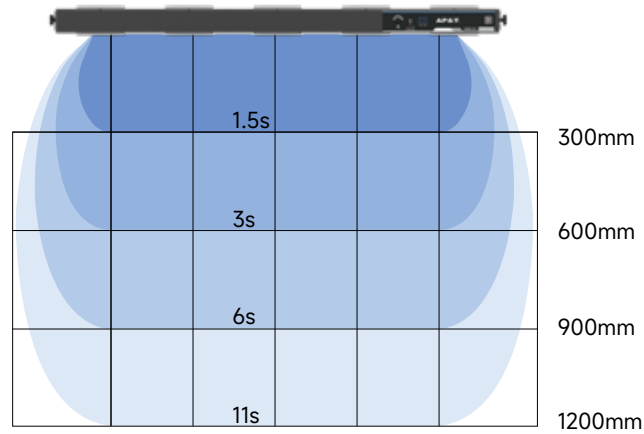

Test standard: ANSI/ESD.STM3.1, SJ/T 11446—2013

Test instrument: Trek 157 charge plate tester

Test voltage: $\pm 1000V \rightarrow \pm 100V$ attenuation

Test environment: humidity 50 \pm 5%; temperature 23 \pm 3 $^{\circ}$ C

Discharging time: Discharge speed within 3 sec when distance is 450mm.

Discharging range: Up to 1300mm width.

Features

Safe / Easy to use / Durable



■ Magnetic net cover

The power is cut off immediately when the net cover is separated, which is convenient for disassembly and maintenance.



■ 4 Electrode needles

4 tungsten electrode needles with longer life time. High speed 7-blade fan transfers larger ion air volume.



■ Built-in cleaning brush

The ionizing air blower automatically brush the needle after it is turned on. During operation, the ionizing air blower automatically brushes the needle every 8 hours without manual brush cleaning and maintenance.



■ Visualization of working status

Red light alarm: Ionizing air blower break down or abnormal high voltage.
Blue light flashing: Debugging or cleaning
Green light on: Ionizing air blower is working normally.

Features

Safe / Easy to use / Durable

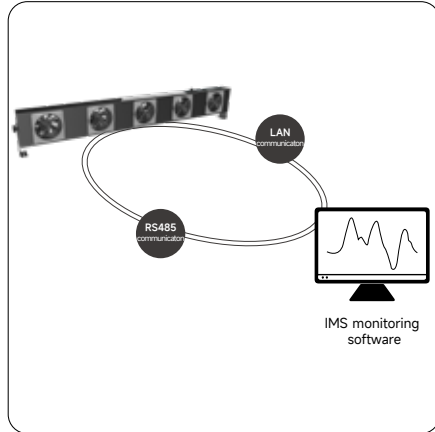

Network Monitoring

Wired network communication realisable and monitor the working status of the air blower.

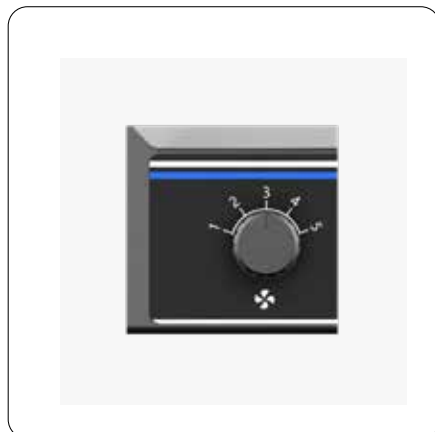

Five speed adjustment

High air volume fan five speed control with stable performance. Air volume output 1.45 times higher than ordinary fans.

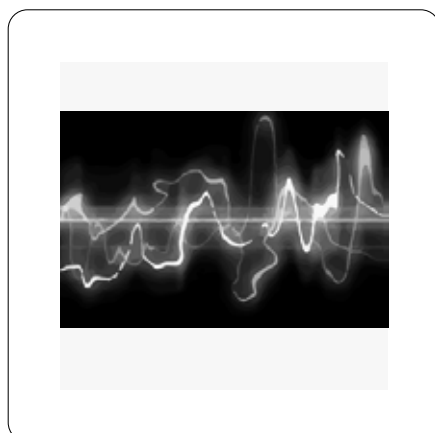

CE Certification

CE certified with electromagnetic protection function and no electromagnetic interference to other equipment. It can also effectively avoid external electromagnetic interference affecting the normal operation of the air blower.

Product Specifications

Product appearance / Product parameter

◆ Product appearance

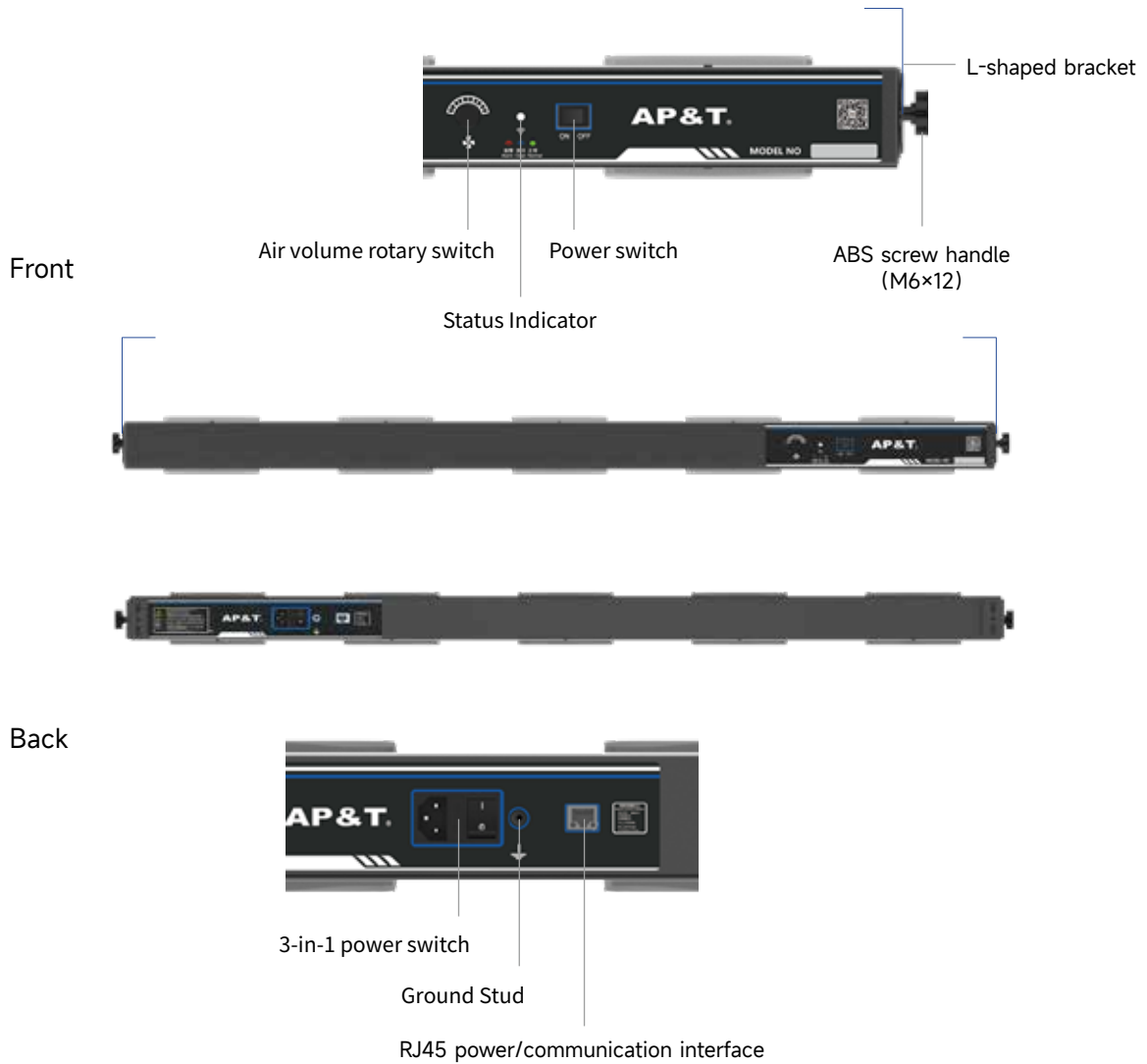

Power interface cable function information		
1	Orange	VCC: +24VDC
2	White-orange	VCC: +24VDC
3	Blue	RS485+B
4	White-blue	RS485+A
5	Green	GND
6	White-green	GND
7	Brown	V_{TH} : Sensor threshold alarm HV_{AL} : Eliminator high voltage alarm
8	White-brown	ACT: Sensor/Eliminator power-on indication Clean: Eliminator cleaning indication
9	Metal shield	PE

Product Specifications

Product appearance / Product parameter

◆ Product Parameter

Model	AP-DJ2715
Input voltage	DC 24V (RJ45 interface) /3 in 1 socket (220VAC 50/60Hz)
Input Current	< 0.3A AC
Output voltage	DC±4KV → ±7KV
Power	< 66W
Ion emission	DC
Emitter electrode	Tungsten
Discharge range	750*1300mm (L*W)
Air volume	≤ 135CFM*5
Noise	Single air outlet ≤ 58dBA (1000mm away from the air outlet)
Ozone thickness	≤ 0.05ppm (150mm away from the air outlet)
Ion balance	≤ ±15V
Discharge speed	≤ 3.0s (450mm away from the air outlet)
Status indicator	Power on/clean operation—blue light flashes
	Normal work—green light (always under monitoring status)
	Fan alarm—red light always on
	High voltage abnormality—red light flashes
	Infrared debugging/cleaning prompt - Blue light flashing
Communication mode	RS485
Working temperature	0°C -50°C
Working humidity	< 70%RH
Dimensions (L*W*H)	1250*67*154mm (Ionizing Air Blower body size)
Shell material	Aluminum powder spraying
Installation accessories	1 pair of L-shape iron powder spray mounting bracket , 1 pair of ABS screw handles (M6×12)
Power adapter	INPUT: AC100—240V 50/60Hz
	OUTPUT: DC24V 2A (Dual RJ45 interface)
Net weight	5.5KG (Including power cord and bracket)
Gross weight	7.2KG
Warranty	1 Year
Certification	CE

Use Of The Product

Product dimension drawing / Installation step / Installation position / Packaging accessories

◆ Product dimension drawing

Unit: mm

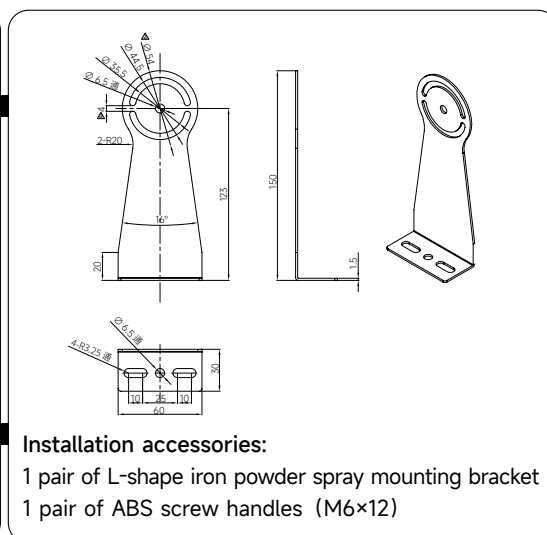
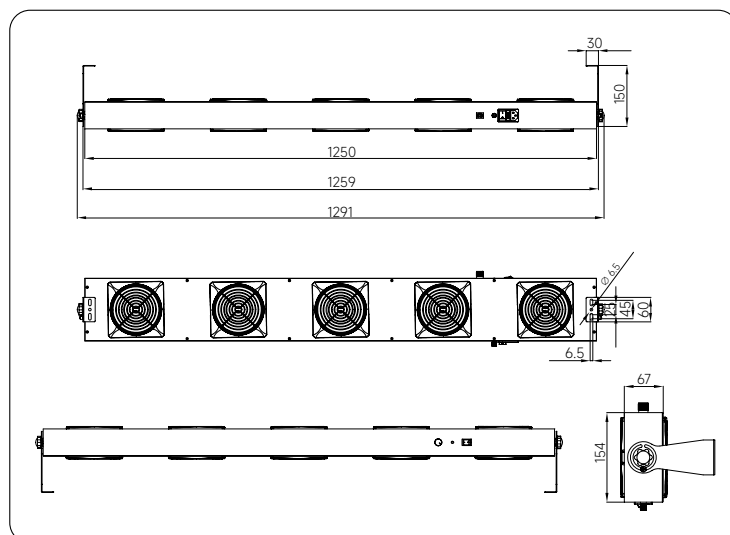



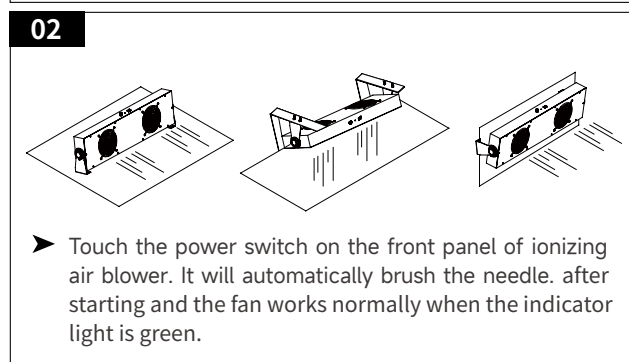
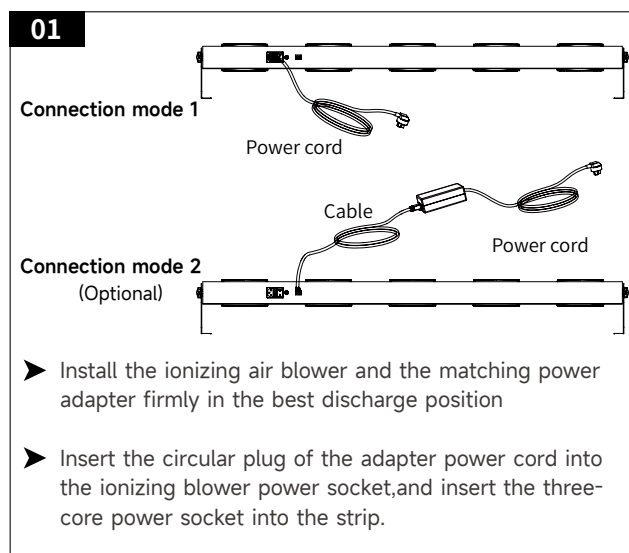

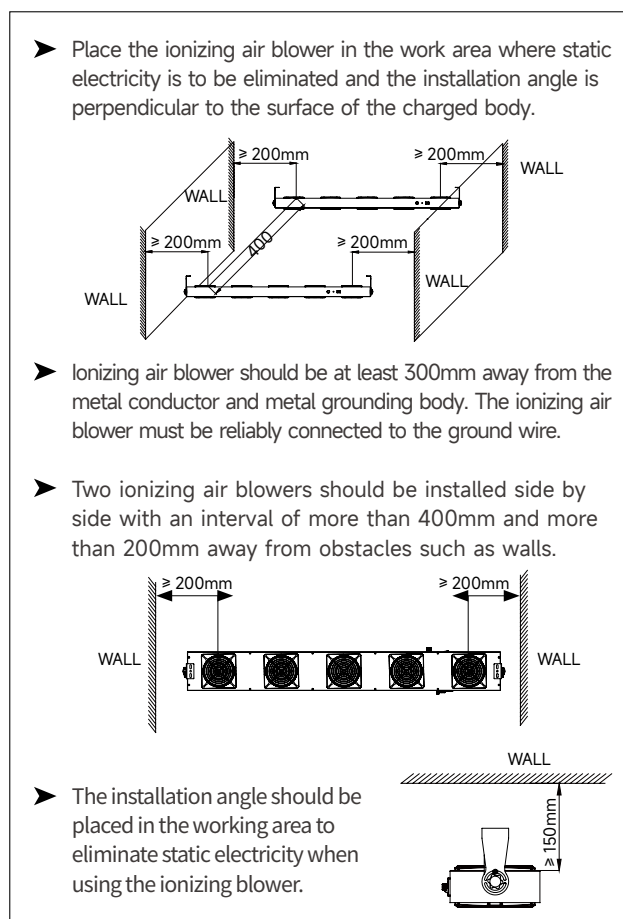

◆ Installation step



◆ Installation position



◆ Packing accessories

Part name	Picture	Part No.	Specification	Qty.
Power adapter		AP2930003	GRT-240200 DC24V 2A P/N:1/2+ 5/6- Port metal PE Size: 123*61*40.5mm (L*W*H)	Optional
National standard power cord		8YXG25110	Standard 1.8m, Optional 3m/5m	1
Power cable		8WXI00004	Standard 2.5m, Optional 5m/10m	Optional
Bracket		AP8032042	1 pair of L-shape iron powder spray mounting bracket	2
Install the screw assembly		AP6480000	M4x8 combination screw, flat gasket, spring washer	2
ABS screw handles		3BSM06120	ABS screw handles (M6×12)	2

▲ Safety warning

- Please read the instruction manual carefully before installing and using this equipment.
- The whole set of equipment must be reliably grounded during use, and the connection resistance of the electrical connection to the AC equipment ground should be less than 1 ohm.
- Do not use this equipment in environment where humidity is > 70%.
- It is strictly forbidden to use this equipment in flammable and explosive environments.
- Unauthorized disassembly of the product is strictly prohibited, internal maintenance and repair must be performed by professionals.
- The product is strictly prohibited to touch liquid during use, otherwise an abnormality may occur and cause electric shock or fire.
- Power must be turned off during inspecting or replacing the product, otherwise it may cause electric shock or fire.
- The product is specially designed to eliminate static electricity. It is strictly forbidden to use it for other purposes. Any abnormal use may cause machine failure, electric shock, fire and other accidents.
- It is strictly forbidden to touch the electrode needles when power is on, otherwise it is easy to cause malfunctions and electric shock accidents.
- The electrode needle is a sharp metal object, please use it with care.
- Please check the specifications of the power supply before powering on the product. Any power supply that does not meet the specifications will cause damage to the product.
- Please check the product power cord/communication cord regularly and replace it immediately if it is damaged. Otherwise it is easy to cause problems such as electric leakage, poor communication, and abnormal operation.

NO	Problems	Reasons	Solutions
1	The indicator on the fan panel is off	Poor contact of the power cable	Check whether the power cable is in good condition and securely connected
		Power supply mismatch	Confirm the power supply specification (INPUT: 100—240VAC 50/60Hz; OUTPUT: 24VDC 2000mA)
2	The electrostatic removal performance decreased obviously	Discharge needle is polluted and damaged	Clean or replace the discharge needle
		The cleaning brush covers the electrode needle	Brush the needle manually with the remote control, or shut down and restart to keep the cleaning brush away from the electrode needle
3	The electrostatic removal performance decreased	There are conductors or other ionizing air blower around	Remove (moving) conductors or other ionizing air blowers
4	High voltage/ion balance alarm (Panel indicator light flashes red)	Electromagnetic interference	Turn off the power switch / unplug the power cable, restart the ionizing air blower
		Abnormal discharge	Confirm whether the electrode needle is close to or touching the metal conductor, and remove foreign objects
		No power supply for high voltage module	Return to factory for maintenance
		High voltage module is damaged	Return to factory for maintenance
		Ion balance alarm	After cleaning the electrode and net cover
5	Fan alarm (Panel indicator red light always on)	The cleaning brush covers the electrode needle	shut down and restart to keep the cleaning brush away from the electrode needle
		Fan fault	Return to factory for maintenance
6	The panel blue indicator always on	The fan power supply circuit is damaged	Return to factory for maintenance
		The magnetic mesh cover is not closed	Check the mesh cover installation and make sure the mesh cover is properly drawn
7	Unable to discharge	High voltage module is damaged	Return to factory for maintenance
		Main-board chip is damaged	Return to factory for maintenance
		Poor grounding / no grounding / chip damage caused by wrong power supply circuit	Check the grounding of the ionizing air blower and plant equipment, and return to the factory for maintenance
8	The product is smoky or burnt	The high-voltage module is damaged or the insulation of the discharge bracket is damaged	Return to factory for maintenance

Maintenance

- The fan should be cleaned and maintained in time according to the use environment and the required electrostatic protection requirements in order to ensure the good performance of the product. That is, gently remove the dust on the electrode, discharge bracket, fan and metal mesh cover with electrostatic brush, dust-free cotton swab, dust-free cloth dipped in anhydrous alcohol. Note:
 - A. Operation must be done 10 minutes after power cut of.
 - B. The cleaning cycle of the electrode needle should be set according to the working environment during use of the fan. It should be appropriately reduced in the environment with more humid and dusty.
 - C. The fan must be powered on after alcohol is completely volatilized after cleaning. No other organic solvent can be used to clean the fan.
 - D. The alloy electrode is a consumable product which is not included in the scope of warranty and will be charged for replacement when repairing.
- Do not press or rotate the control buttons on the fan panel too hard; otherwise, the device will be permanently damaged.
- If the working indicator light on the front panel of the fan is off or red, it should be stopped and repaired by professional maintenance personnel. It can be used only after the electrical performance index is normal.

After-sales service

- AP-DJ2715 ionizing air blower has undergone rigorous testing and aging treatment before ex-work. Its performance has completely reached the relevant indicators marked in the usage instruction.
- AP&T makes a commitment to the customer that any defective parts inspected by AP&T will be repaired or replaced free of charge within one year from the date of purchase. However, this commitment does not apply to:
 - 1. The device is incorrectly used or installed.
 - 2. Damage caused by negligence or accident during use;
 - 3. Modified, disassembled or repaired by other service departments not authorized by Anping Company.
- AP&T shall not be liable for any incorrect use of the products except for repair or replacement of parts as specified above.

